

# the WHITE line of desire

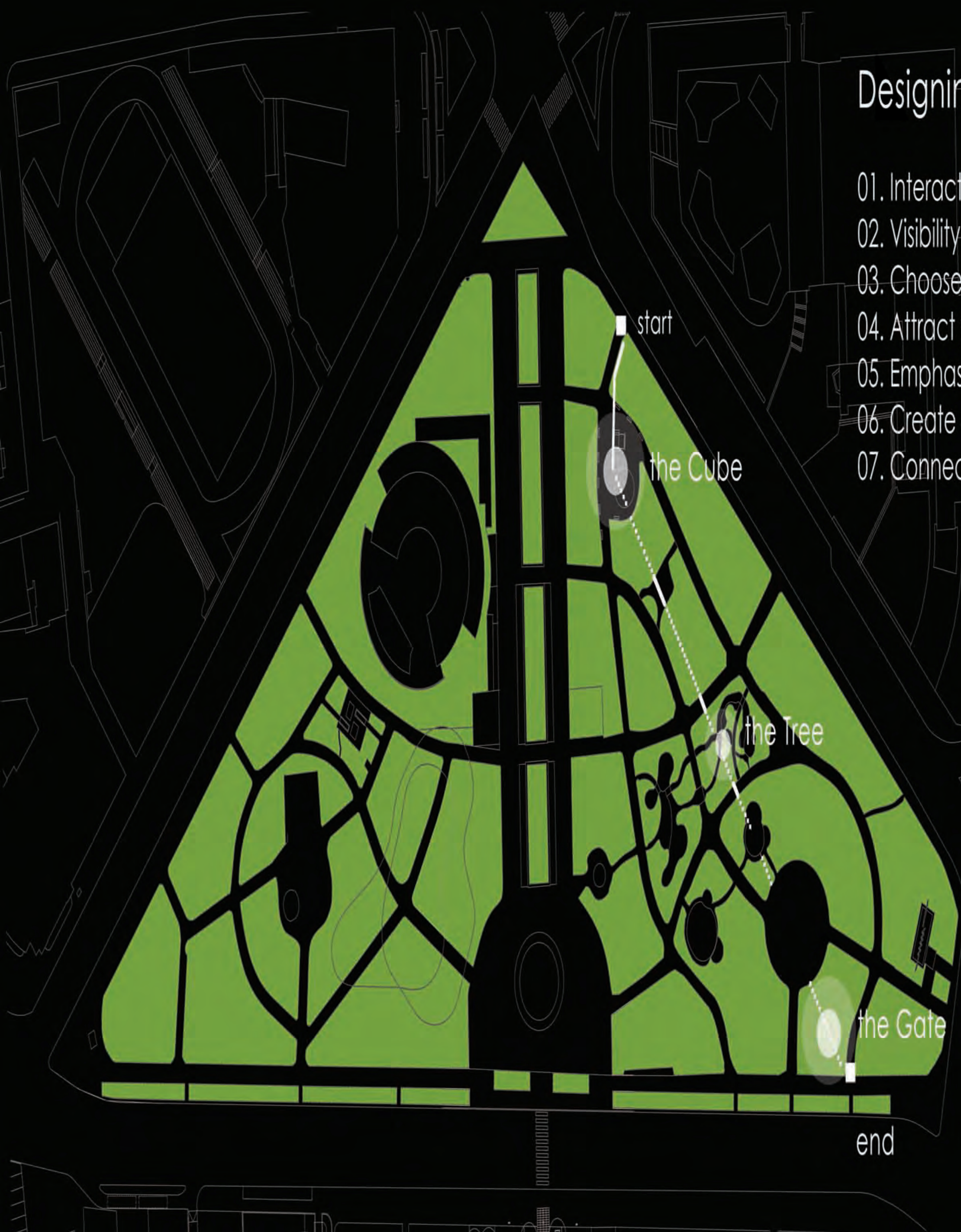

## Designing Criteria

01. Interactive construction
02. Visibility from the street
03. Choose an open and safe space
04. Attract young people
05. Emphasize the entrance
06. Create a path
07. Connect points of interest

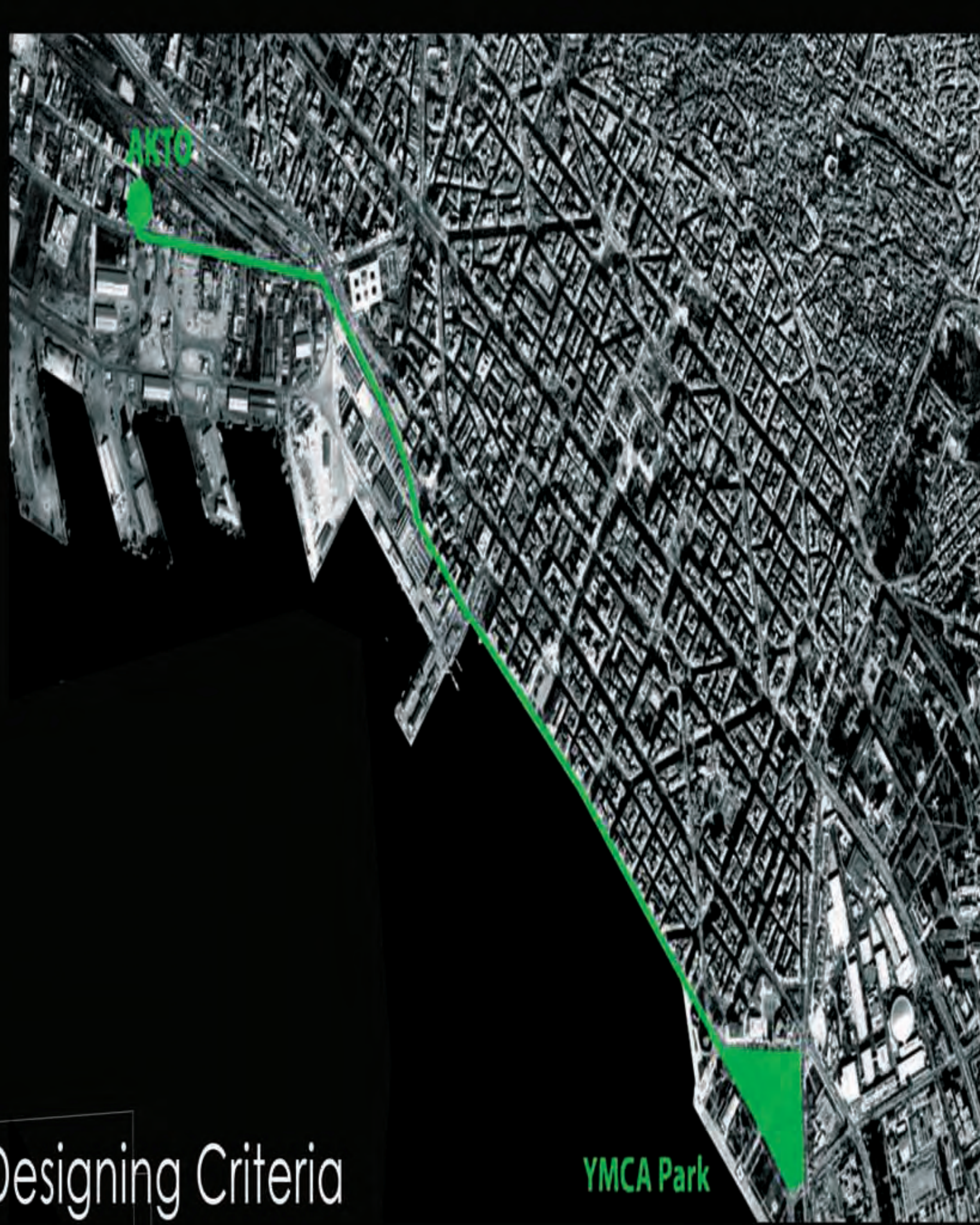

start

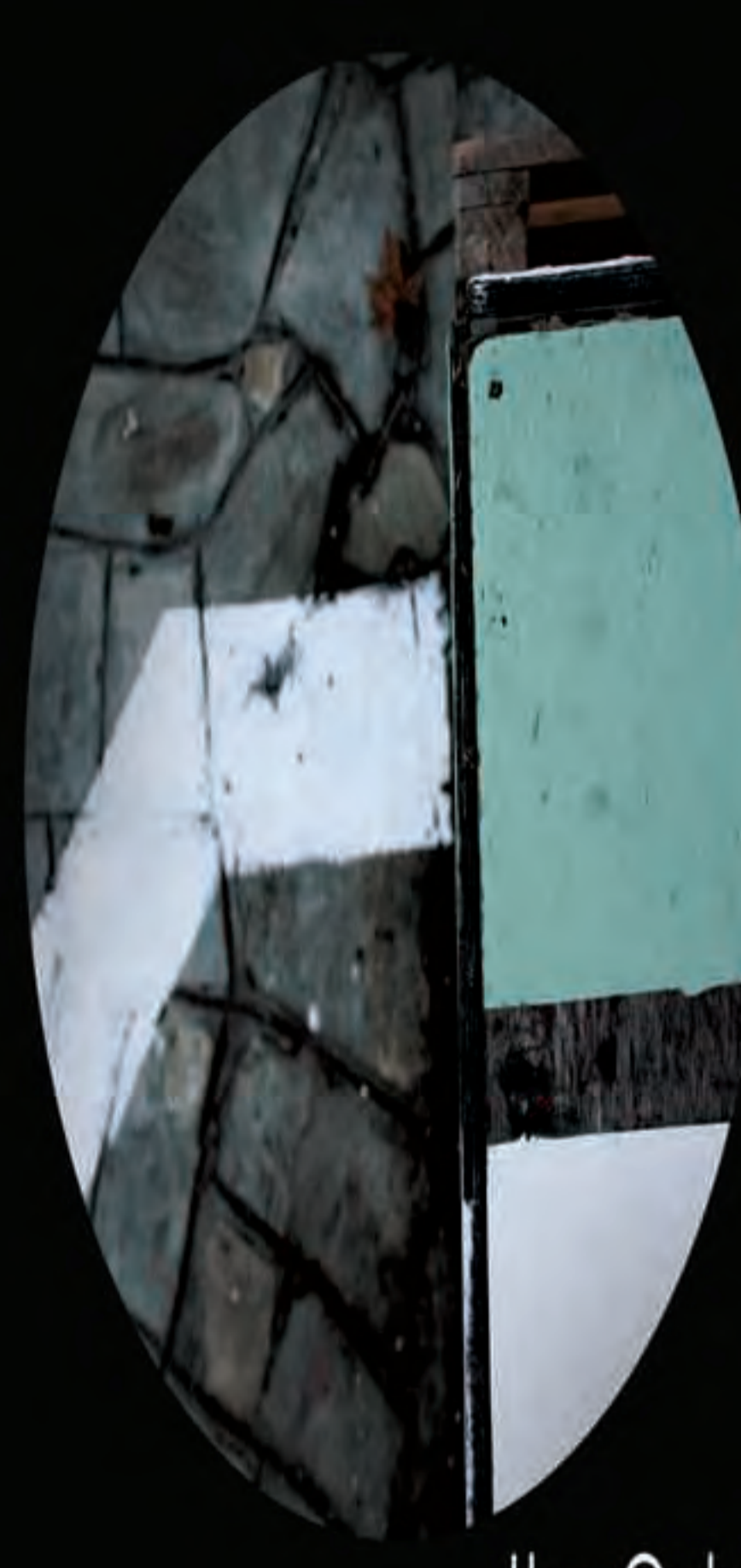

the Cube



the Swing



the Gate

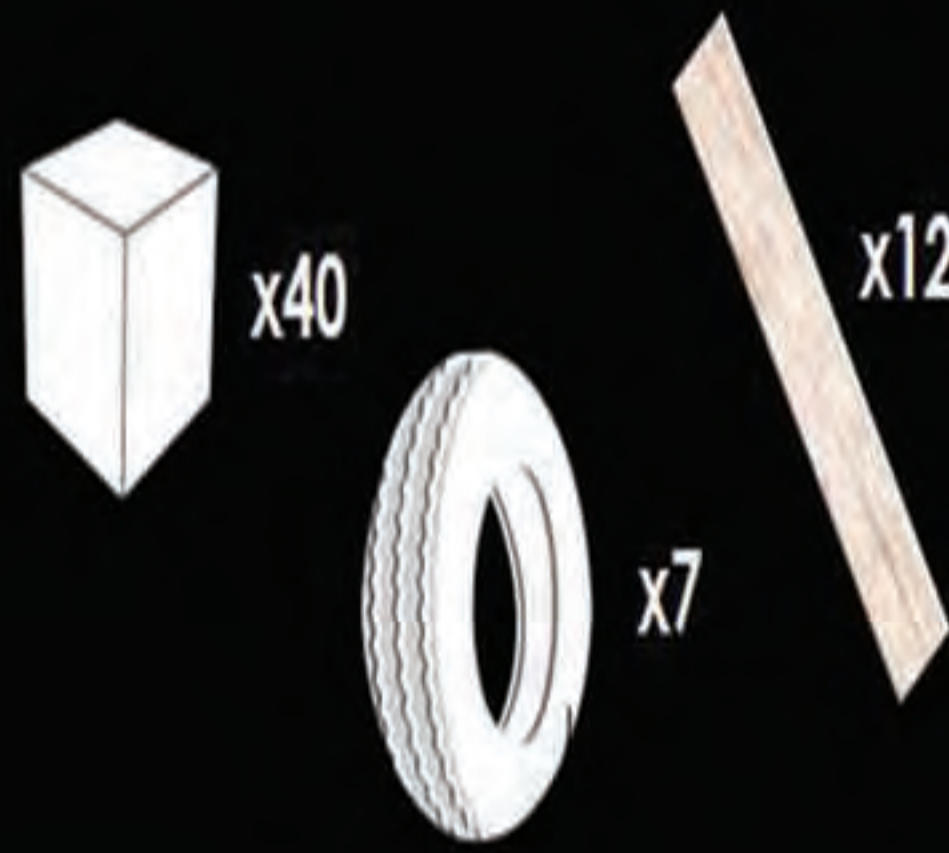

the Tree



current situation



15 pallets



11 tires

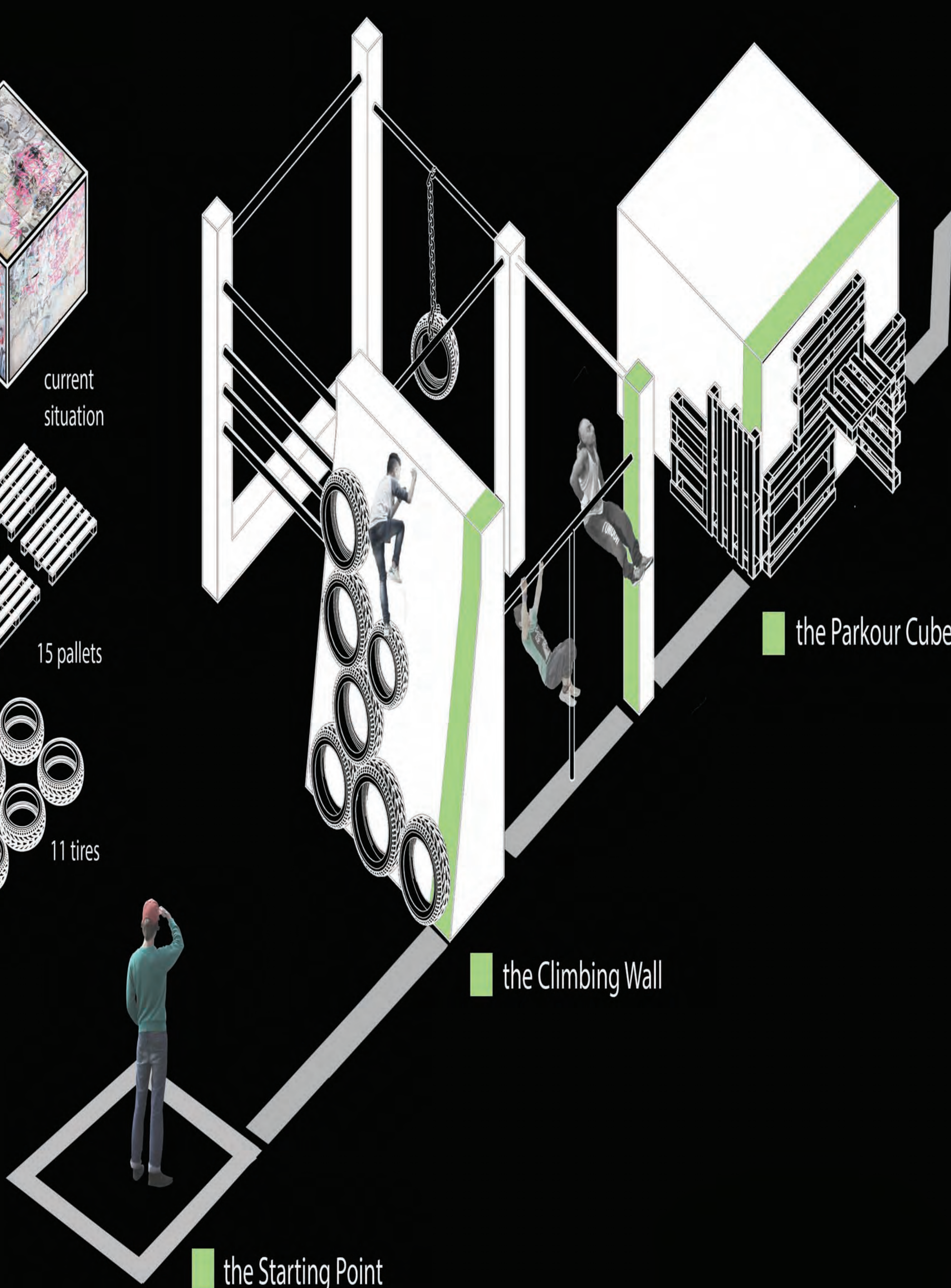

the Starting Point

the Climbing Wall

the Parkour Cube